

# 角フリューム

(150, 300, 500)

単位：mm

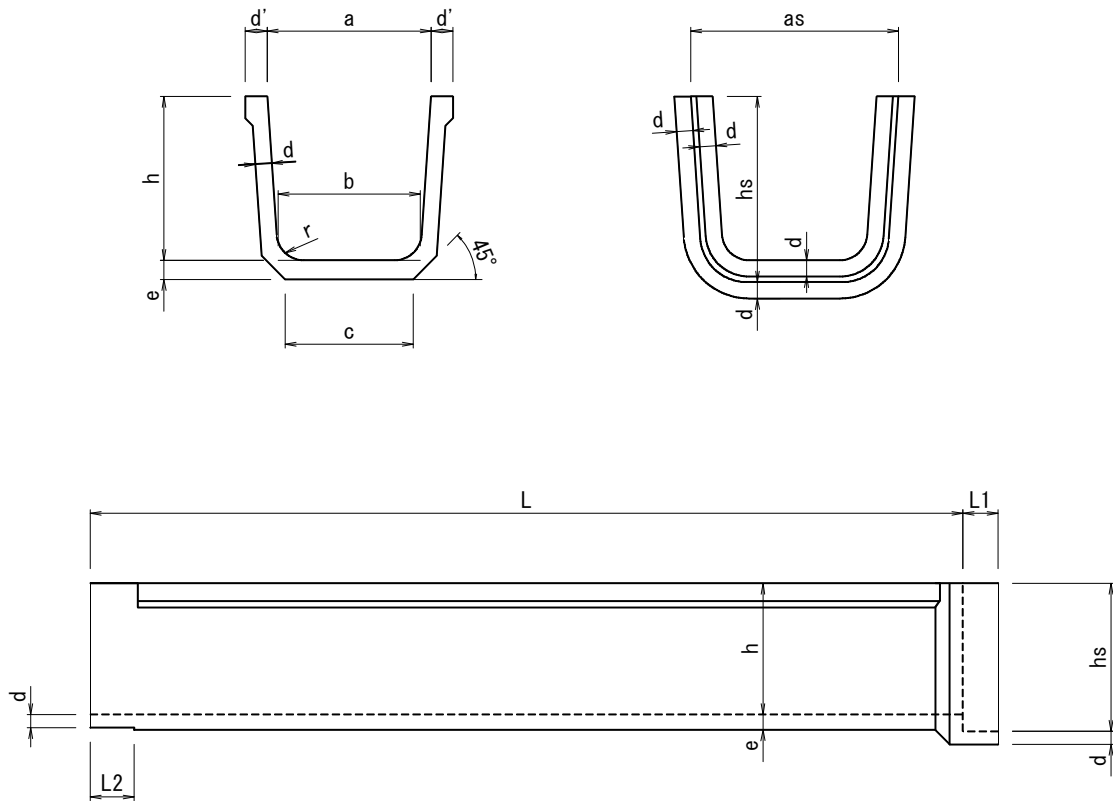

単位：mm

呼び	寸法												参考重量 (kg)	
	a	b	c	d	d'	e	h	hs	as	r	L	L1		L2
150	150	130	120	20	30	23	150	178	206	30	1995	60	80	49
200	200	173	143	25	30	29	200	233	266	50	1995	60	80	73
250	250	217	187	25	35	29	250	283	316	50	1995	60	80	100
300	300	260	234	30	40	35	300	338	376	50	1995	80	100	145
350	350	303	277	30	40	35	350	388	426	50	1995	80	100	170
400	400	347	329	40	50	46	400	448	496	50	1995	80	100	260
450	450	390	350	40	50	46	450	498	546	70	1995	80	100	280
500	500	433	403	50	60	57	500	558	616	70	1995	80	100	382