

角フリューム

(200, 250, 350, 400)

単位：mm

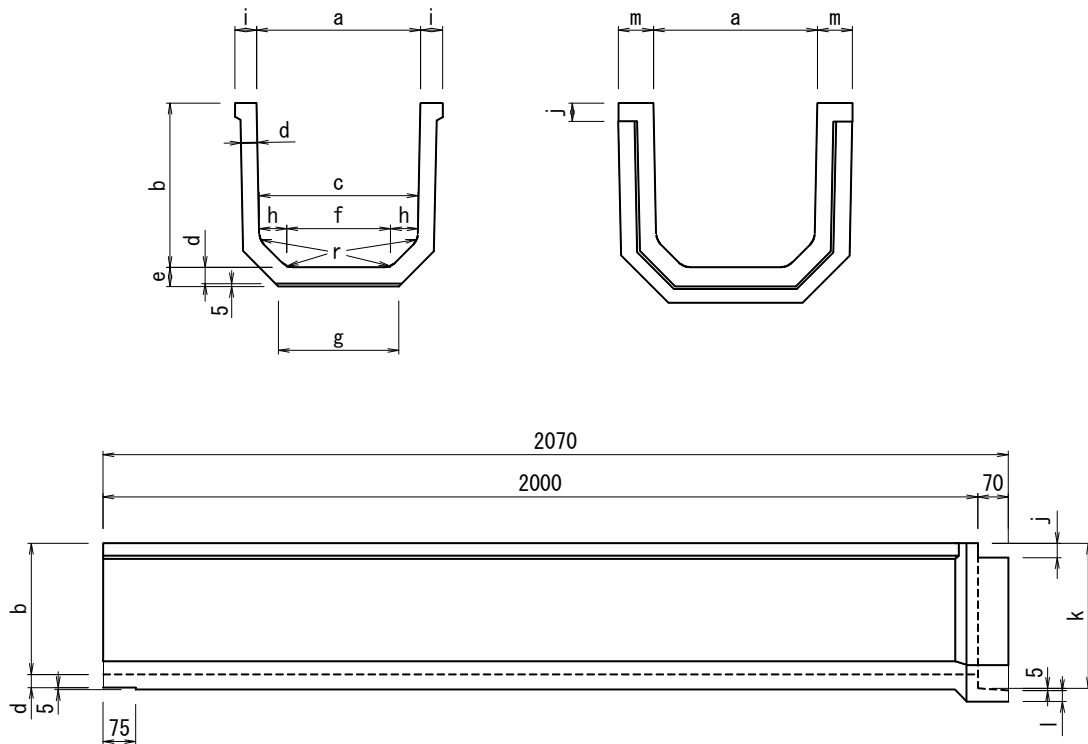

単位：mm

呼び	寸法														参考重量 (kg)
	a	b	c	d	e	f	g	h	i	j	k	l	m	r	
150	150	150	140	20	25	80	100	30	30	28	172	20	48	10	49
200	200	200	190	20	25	130	150	30	30	28	222	20	48	10	73
250	250	250	240	25	30	160	185	40	35	33	277	25	59	30	100
300	300	300	290	30	35	190	220	50	40	33	332	25	64	30	145
350	350	350	335	30	35	215	245	60	40	33	382	25	64	30	170
400	400	400	385	40	45	265	305	60	50	38	442	30	79	30	260
450	450	450	430	40	45	310	345	60	50	38	493	40	89	30	280
500	500	500	480	50	55	360	405	60	60	38	553	50	109	30	382